

No.	Plan	Article	Qty
1	E00075734	---	1
2	P00049512	3991104	1
3	P00049511	3990780	1
4	T001090	T001090	1
5*	P00019685	T001069/T001068	1
6	T001263	T001263	1
7	P00122495	T001261	1
8	T001274	T001274	1

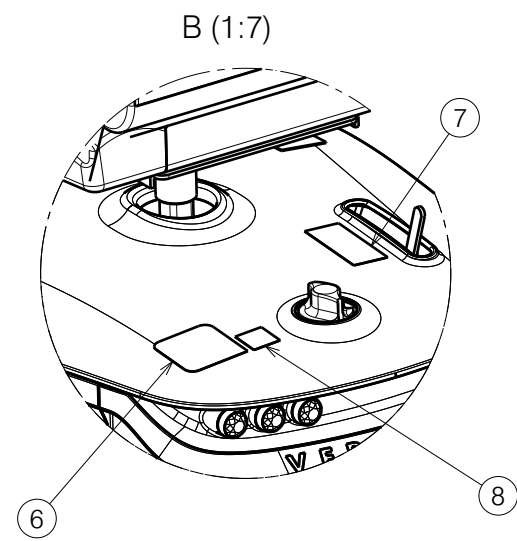
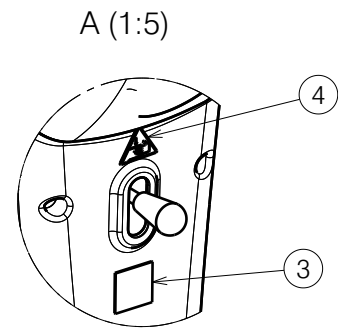
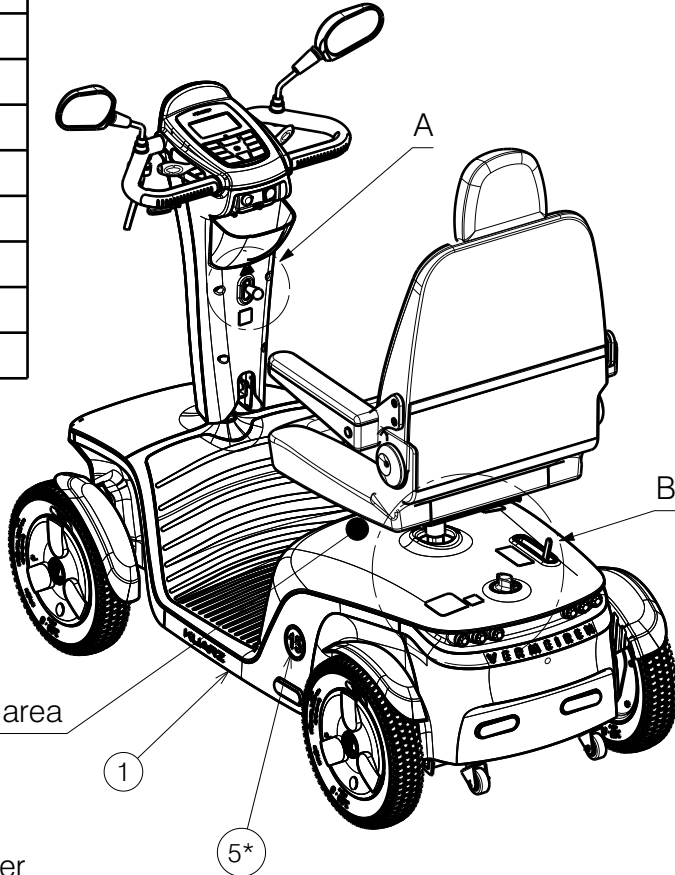

\* Only for the Swiss market  
 JIG P0122198 for position 6, 7, 8  
 JIG P0121969 for certification label

Certyfication label area

Stick on inner wall of Battery Cover  
 in showed place

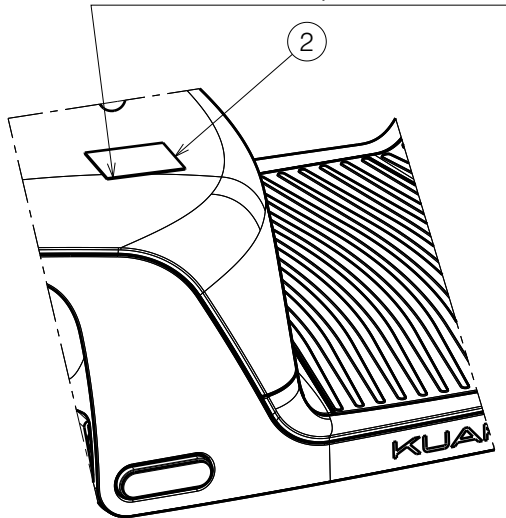

NOTICE: THE INFORMATION CONTAINED ON THIS DRAWING IS PROPRIETARY TO VERMEIREN GROUP AND SHALL NOT BE DISCLOSED IN WHOLE OR IN PART, OR USED FOR ANY DESIGN OR MANUFACTURE, EXCEPT WHEN SUCH USER POSSESSES DIRECT WRITTEN AUTHORISATION FROM VERMEIREN GROUP.

SV KUARZ STICKER COFIGURATION				Plan No.
				E00122492/A.1
Scale:	1:15	Drafted	Verified	Confirmed
Date	19/02/2026	19/02/2026	19/02/2026	19/02/2026
Initials	BK	MK	MK	

