

No.	Plan	Article	Qty
1	P00071639	29987...	1
2	3M Dual lock 12x25 mm	2998521	4
3	XC00529	3992256	2

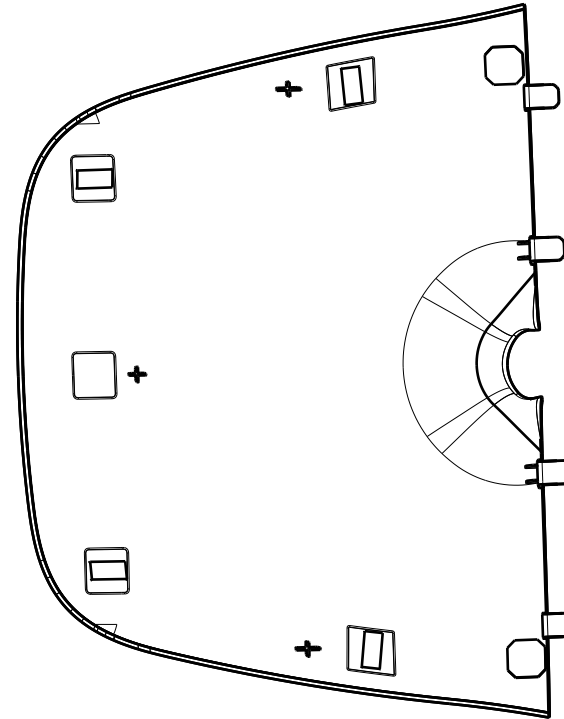
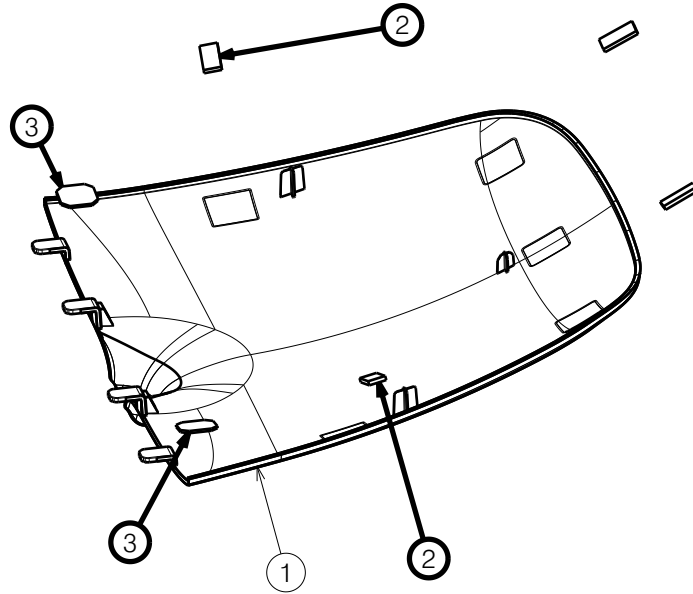

Before stick 3M Dual Lock prepare surface on plastic part:

1. Roughen the surface by abrasive pad
2. Clean surface with Isopropyl Alcohol (IPA), propan-2-OL.
3. Press 3M Dual Lock after stick

NOTICE: THE INFORMATION CONTAINED ON THIS DRAWING IS PROPRIETARY TO VERMEIREN GROUP AND SHALL NOT BE DISCLOSED IN WHOLE OR IN PART, OR USED FOR ANY DESIGN OR MANUFACTURE, EXCEPT WHEN SUCH USER POSSESSES DIRECT WRITTEN AUTHORISATION FROM VERMEIREN GROUP.

SV KUARZ FRONT COVER COMPLET			
Scale: 1:5	Drafted	Verified	Confirmed
Date	02/12/2024	13/03/2026	13/03/2026
Initials	BK	PM	MK

---
Plan No. E00094479/B.1
